



# Johnson-Promident

CARBIDE BURS

DIAMOND BURS

FINISHING & POLISHING

JOHNSON-PROMIDENT UNIVERSITY

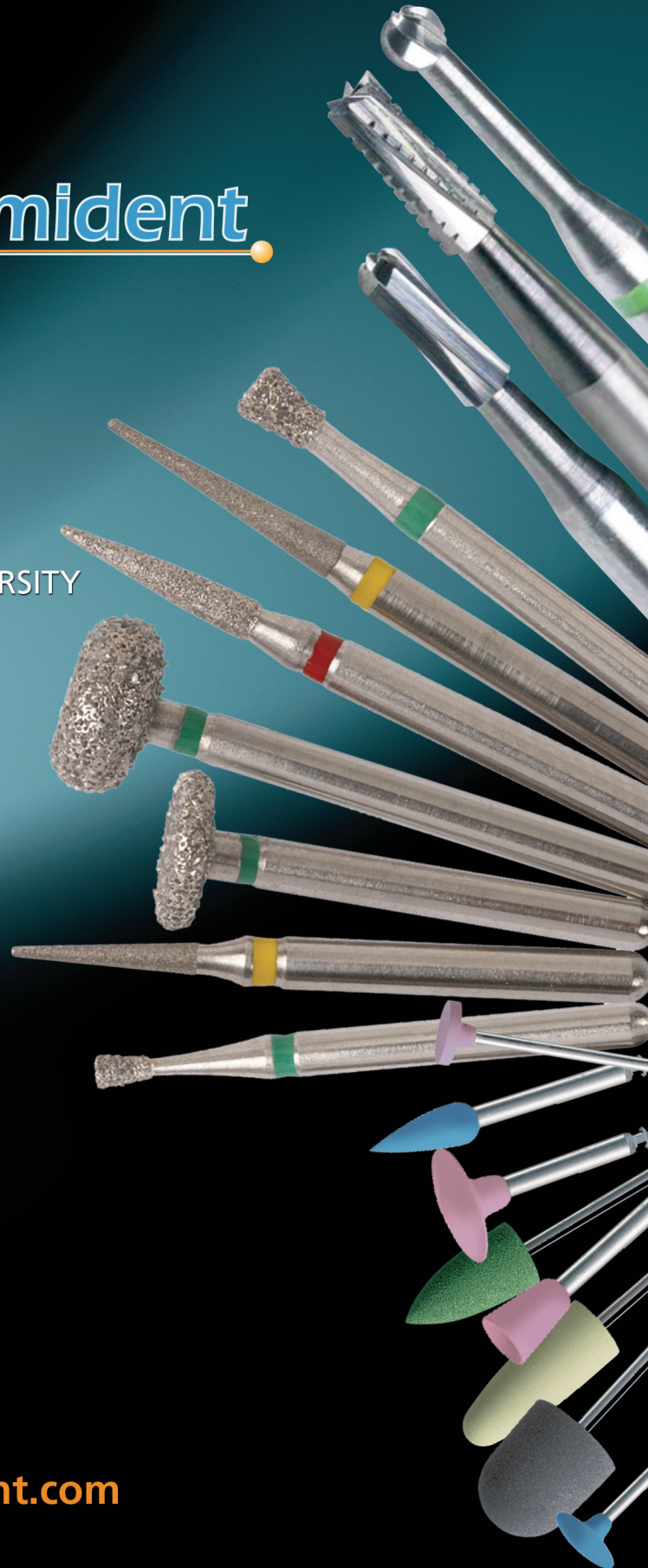

[www.johnsonpromident.com](http://www.johnsonpromident.com)

---

# TABLE OF CONTENTS

Johnson-Promident is proud to now be your one-stop shop for all rotary instruments. Nowhere else on earth will you find as comprehensive a selection as we offer, from carbides to diamonds to finishing and polishing instruments.

Not only do we provide a single source for all rotary instruments, but our instruments offer both leading quality performance and amazing value. An independent evaluation from *Dental Product Shopper* magazine rated our carbides as a Best Product of 2012, with the highest rating ever given to a carbide bur. We have products that match the newest technologies in composite polishers, such as Dentsply's Enhance and PoGo. We also have the head-to-head comparable products to the industry leaders, like 3M's Sof-Lex discs and strips and Brasseler's multi-use diamonds.

Our burs are designed and manufactured to consistently deliver the best performance and durability. We are extremely proud of the value we provide, not just through the outstanding quality of our products but also through our great prices, same day shipping, and tiny backorder rate. We are ready to support you with the best price on the best products!

## contents

### Get Educated!

#### *Johnson-Promident University*

• What is a Rotary Dental Instrument? .....	1
• Carbide Burs .....	1
• Carbide Burs vs. Diamond Burs .....	3
• Diamond Burs .....	4
• Finishing and Polishing Instruments .....	5
• Usage and Maintenance .....	6
• Numbering Systems .....	7
• Reading the Charts .....	8

### Our Products

<i>Carbide Burs</i> .....	9
• Features and Benefits .....	9
• Complete Product Listings .....	10
<i>Diamond Burs</i> .....	15
• Features and Benefits .....	15
• Complete Product Listings .....	16
• Cross-Reference Charts .....	20
<i>Finishing and Polishing Instruments</i> .....	22
• Complete Product Listings .....	22



## Get Educated! Johnson-Promident University

### WHAT IS A ROTARY DENTAL INSTRUMENT?

A rotary instrument is an instrument that enables dental health professionals to remove or reduce tooth matter and dental materials and to shape teeth during various procedures.

The main types of rotary dental instruments are:

1. **Burs** – used in a high speed or low speed handpiece for cutting; usually made of tungsten **carbide** or **diamond**.

There are three parts to a bur:

- **Head** – the working/cutting part; comes in many shapes and sizes
- **Neck** – the narrow portion connecting the shank and the head; transmits the rotational force
- **Shank** – the part that fits into the handpiece; comes in different types to fit different handpieces and also comes in different lengths for different usages.



The head of the bur contains the blades or diamond grit, which remove material. The blades can be positioned at different angles to change the way the bur operates. Blades placed at more obtuse angles produce a negative rake angle which will increase the strength and longevity of the bur. Blades placed at more acute angles produce a positive rake angle; this results in a sharper blade, but one which dulls more quickly. Various diamond grits can be applied over a smooth shape for more or less aggressive material removal.

2. **Finishing and Polishing Instruments** – generally used in a low speed handpiece to reduce or shape material and finish or polish surfaces. These include discs, strips, cups, points, and mounted and unmounted stones.

## Did You Know?

*Dentists typically spend between \$2,500 and \$8,000 per year on rotary instruments. For some dental sales reps, rotary instruments represent as much as 25% of their annual sales.*

### CARBIDE BURS

Carbide burs are made of tungsten carbide, a metal that is extremely hard (about three times stiffer than steel) and can withstand high temperatures. Because of their hardness, carbide burs can maintain a sharp cutting edge and be used many times without becoming dull. However, carbide burs are brittle and have a tendency to fracture under pressure. They are best operated at high speeds with light pressure.

Carbide burs are used most commonly for excavating and preparing cavities, finishing cavity walls, finishing restoration surfaces, drilling old fillings, finishing crown preparations, contouring bone, removing impacted teeth, and separating crowns and bridges.

Carbide burs are defined by their shank and by their head. The type of handpiece being used determines which type of shank is needed. The procedure to be performed determines the type of cutting design/head shape that is chosen.





## Types of Carbide Bur Shanks

The three main types of shanks are Friction Grip (FG), Right Angle (RA) (also known as Latch-Type), and Handpiece (HP). *It is important to know which type of shank you want when choosing a bur because each type is designed to fit into a certain type of handpiece.*

### FRICITION GRIP (STANDARD LENGTH) (FG)



- For use in high speed handpieces and *friction grip* low speed contra angle heads.
- Has the smallest diameter shank of all the types of carbide burs; the end of the shank is smooth and is held in place in the handpiece by friction against a chuck.
- The most commonly used operative bur in many offices.

### FRICITION GRIP (SHORT SHANK) (FG SS)



- For use in high speed handpieces (with miniature heads ONLY) and *friction grip* low speed contra angle heads.
- Has a shank that is the same diameter as a standard friction grip bur but is almost 20% shorter; also held in place in the handpiece by friction.
- For use when better access to the posterior region is needed, especially when patients cannot open their mouths wide enough.

### FRICITION GRIP (LONG) (FG LONG)

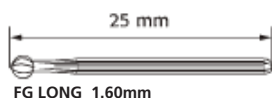

- For use in high speed handpieces and *friction grip* low speed contra angle heads.
- Has a shank that is the same diameter as a standard friction grip bur, but the total length of the shank and head is about 30% longer; also held in place in the handpiece by friction.

### FRICITION GRIP (SURGICAL) (FG SURGICAL)

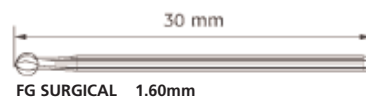

- For use in high speed handpieces and *friction grip* low speed contra angle heads.
- Has a shank that is the same diameter as a standard friction grip bur but is more than 50% longer; also held in place in the handpiece by friction.
- Often used when a longer length and better visibility are required, including in extraction and root canal procedures.

### RIGHT ANGLE/LATCH-TYPE (RA)

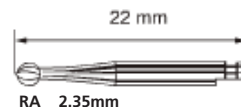

- For use in latch-type contra angle heads in low speed handpieces.
- Has a notch on the end that allows a hook to latch onto it in the head of the handpiece.
- Provides greater control when cutting dentin or enamel.

### RIGHT ANGLE/LATCH-TYPE (SURGICAL) (RA SURGICAL)



- For use in latch-type contra angle heads in low speed handpieces.
- Has a notch on the end that allows a hook to latch on to it in the head of the handpiece.
- Has a shank that is the same diameter as a standard right angle bur but is about 20% longer.

### STRAIGHT HANDPIECE (HP)

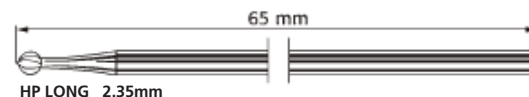

- Used in straight attachments/nose cones and Doriot-type low speed handpieces.
- Has a large, long shank.
- Used primarily in dental laboratories and to make adjustments to material outside the mouth.





## Head Diameter / Sizes

Per ISO standards the diameter of a rotary instrument is defined as the widest part of the cutting surface.

$\varnothing$ 1/10mm $\varnothing$ mm $\varnothing$ inches	005 0.5 0.020	006 0.6 0.024	007 0.7 0.028	008 0.8 0.031	009 0.9 0.035	010 1.0 0.039	012 1.2 0.047	014 1.4 0.055	016 1.6 0.063	018 1.8 0.071	021 2.1 0.083	023 2.3 0.091	025 2.5 0.098	027 2.7 0.106	029 2.9 0.114
$\varnothing$ 1/10mm $\varnothing$ mm $\varnothing$ inches	031 3.1 0.122	033 3.3 0.130	035 3.5 0.138	037 3.7 0.148	040 4.0 0.157	042 4.2 0.165	045 4.5 0.177	047 4.7 0.185	050 5.0 0.197	055 5.5 0.217	060 6.0 0.236	065 6.5 0.256	070 7.0 0.276	075 7.5 0.295	080 8.0 0.315

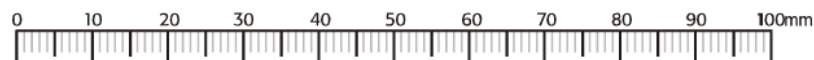

### Types of Carbide Bur Shapes

The cutting end of the bur is named by its shape. There are a variety of shapes available, each suited to a particular task. Some of the most popular are round, pear, inverted cone, straight fissure, and tapered fissure.

Different flute angles also create different cutting characteristics and make a particular bur more appropriate for a certain task. **Operative**, or cavity preparation burs, have deep and wide flutes which allow for more aggressive enamel cutting with higher speed and efficiency. These operative burs are usually either *straight-bladed* (plain) or *crosscut*. Straight-bladed burs cut smoothly but more slowly, especially with harder materials. Crosscut burs have additional cuts across the blades (these are the crosscuts) to create increased cutting efficiency. While the benefit of these extra blades has been minimized in recent years with the advent of high-speed handpieces (which cut more efficiently), crosscut burs can generally cut more quickly because debris does not build up on the bur.

**Trimming and finishing** burs have more blades than operative burs, and the blades are closer together and shallower, which makes these burs ideal for the fine finishing and polishing of dental materials.

Each type of bur shape has a **number designation**, with the head of the bur generally increasing in size as the number gets larger within a particular shape series. For example, round burs come in sizes from  $\frac{1}{4}$  to 8, with 8 having a much larger head than  $\frac{1}{4}$ .

### CARBIDE BURS VS. DIAMOND BURS

Restorative tooth preparation requires complete removal of enamel, existing restorative materials, and caries. **Diamond burs** will safely accomplish this and are unlikely to cause enamel fracture. However, while cutting through porcelain is best accomplished with diamonds, they are slow to cut enamel and slower at cutting metal-based restorations or sectioning cast metal copings or crowns. Diamond surfaces can also fill with debris and clog, wear smooth, and cause burnishing and overheating. Therefore, **carbide burs** are more often used to easily accomplish these tasks. Carbide burs should be used to trim and finish macro-filled composites and hybrid composites.

*Carbides and diamonds also produce different outcomes:* carbide burs slice or chip away at material, leaving the tooth surface smooth and more aesthetically pleasing. Diamond burs grind away at material, leaving a rough tooth surface which requires more polishing in the end.



## DIAMOND BURS

Diamond burs are generally used for reducing tooth structures to place crowns or porcelain veneer. Diamonds may also be used to smooth, refine, and polish composite or porcelain material.

Diamond is the hardest of all known materials. When bonded to stainless steel through a special metallurgical process, it can be used to create a cutting edge with superior cutting ability and durability. However, compared with carbide burs, diamond burs usually have a more pronounced decrease in cutting effectiveness over time leading to a shorter lifespan.

### Types of Diamond Bur Shapes

Unlike carbide burs, which are available in a variety of shank types, diamond burs are most commonly friction grip type because they are used primarily in high speed handpieces. However, similar to carbide burs, they come in a variety of head shapes and sizes.

### Diamond Bur Grits

Diamond burs also come in a variety of grit sizes. *Coarse* and *super-coarse* diamond grits for tooth reduction are the most popular, with *fine* and *super-fine* for polishing and smoothing a distant second. Grinding and polishing diamonds should be used to trim and finish micro-filled composites. Coarse grinding tools leave behind striations; fine and extra fine diamonds are suitable for finishing.

#### Diamond Grit Sizes

Code	Description	μ
<b>SF</b>	<b>Super Fine</b>	<b>30</b>
<b>F</b>	<b>Fine</b>	<b>50</b>
<b>M</b>	<b>Medium</b>	<b>107-120</b>
<b>C</b>	<b>Coarse</b>	<b>150-180</b>
<b>SC</b>	<b>Super Coarse</b>	<b>180-250</b>

Diamond Bur Shapes					
Description	Shape	ISO	Description	Shape	ISO
Barrel	811	037, 038	Pear	822, 830	237, 238, 239
Cylinder Rounded Shoulder	835KR, 836KR, 837KR, 880, 881, 881KS	146, 156, 157, 158	Pointed Cylinder	879, 884, 885, 886,	129, 130, 131
Depth Cutting	834	552	Round	801	001
Double Inverted Cone	806, 813	019, 032,	Round + Neck	802	002
Egg/Football	368, 369, 379	243, 257, 277	Surgical Length Round	801L	001(316)
End Cutting	839, 840	150	Round End Cylinder	838, 881	139, 141
Flame	390, 860, 861, 862, 863	247, 248, 249, 250, 254, 297, 298	Round End Taper	849, 850, 850L, 855, 855L, 856, 856L	196, 197, 198, 199
Flat End Cylinder	835, 836, 837	108, 109, 110, 111, 141	Round Wheel	909	066, 067, 068
Flat End Taper	845, 846, 847, 848	169, 170, 171, 172, 173	Safe End	851	220
Gingival Curettage	877K, 878K, 879K,	297, 298	Separation	889	169, 540
Gross Reduction	651, 652, 654, 655	511, 512, 513	Specials - Cool Cut	T368, T850, T855, T855L, T862, T863	197, 199, 249, 257
Inter Proximal	392	465	Taper Rounded Shoulder	845KR, 846KR, 847KR	544, 545, 546
Inverted Cone	805, 807	010, 225	Torpedo Cylinder	877, 878, 879	288, 289, 290
Knife Edge	825	304	Wheel	818	041, 042
Needle	852, 858, 859, 859L, 889	160, 170, 171, 172, 173, 198, 199	X-Mas Tree	852	161

### Single-Use vs. Multi-Use

Diamond burs come in two types: single-use and multi-use. *Single-use* diamond burs provide the convenience of an individually packaged pre-sterilized diamond and a new sharp instrument with each use. *Multi-use* diamonds are designed to be re-used for a number of procedures and hence are more economical. There are many more shapes and grits available in multi-use diamonds.



## FINISHING AND POLISHING INSTRUMENTS

Finishing and Polishing Instruments are used to finish and polish dental material surfaces to improve their aesthetic quality.

There are many different types of finishing and polishing instruments, and many instruments have overlapping capabilities, which can make it very difficult to choose. We have tried to present the trade-offs to give you guidance on choosing the best instrument for the procedure.

There are three main materials that these instruments are made of:

1. Aluminum Oxide
2. Silicon Carbide
3. Diamond Grit

The non-diamond abrasives provide good results for removing, contouring, and polishing dental materials. Silicon carbide is generally the preferred abrasive for porcelain, acrylic, and gold, as it will not cause discoloration. Aluminum oxide is the preferred choice for composites and enamel.

Diamond abrasives are more expensive, last longer, have a faster working time, and provide a mirror finish. These instruments are preferred for porcelain, ceramic, zirconia, and metals.

Just like diamonds and carbides, finishing and polishing instruments come in a range of shapes that are suited for certain materials, procedures, or restoration areas. *So the choice of instrument material and shape will be driven by both the procedure and the dental material to be worked with.*

Flexible mylar discs and strips made of aluminum oxide (called **composite discs/strips**) are the most popular choice for finishing and polishing composites.

**Diamond strips** are a reusable, long-lasting alternative to the mylar strips for interproximal finishing and polishing on all materials.

Also for composites, there are **diamond single-step and two-step** systems for practitioners who prefer to use point- and cup-shaped instruments. These can be disposable single-use items or autoclavable multi-use instruments. Single-use items provide convenience, while multi-use instruments are more economical. The two-step systems require more time but should provide a higher luster polish to the restoration.

**Porcelain polishers** generally come in three grits (coarse, medium, and fine) and can be made from aluminum oxide or diamond. The aluminum oxide porcelain polishers are more economical but are less durable and procedures take longer. The diamond porcelain polishers are more effective on the newest restorative materials. Both types offer points, cups, and discs to suit all procedures.

Silicon carbide is the preferred material for **amalgam/gold polishers** and **acrylic polishers** because it won't cause discoloration. These polishers come in a variety of shapes suitable for these materials.

Grinding and finishing abrasives and cutting discs provide fast contouring and finishing. They are made of aluminum oxide, silicon carbide, and diamond to best work with specific dental materials: **Green stones** (silicon carbide) for porcelain, composites, and gold/silver, **white stones** (aluminum oxide) for enamel, composites, and porcelain, and **diamond abrasives** for ceramic, zirconia, and aluminum restorations.

### Finishing and Polishing Instruments Usage Guide

PROCEDURE	MATERIAL					
	COMPOSITE	PORCELAIN/ CERAMIC	GOLD/ AMALGAM	ACRYLIC	ENAMEL	ZIRCONIA
<i>Grinding/ Finishing Abrasives</i>	Green/White Stones	<ul style="list-style-type: none"> <li>• Diamond Abrasives</li> <li>• Green and White Stones</li> </ul>	Green Stones	White Stones	White Stones	Diamond Abrasives
<i>Polishing</i>	<ul style="list-style-type: none"> <li>• Composite Discs/Strips</li> <li>• Single and Two-Step Composite Polishers</li> </ul>	<ul style="list-style-type: none"> <li>• Porcelain Polishers</li> <li>• Diamond Strips</li> </ul>	Amalgam/ Gold Polishers	Acrylic Polishers	<ul style="list-style-type: none"> <li>• Composite Discs/Strips</li> <li>• Single and Two-Step Composite Polishers</li> </ul>	<ul style="list-style-type: none"> <li>• Diamond Porcelain Polishers</li> <li>• Diamond Strips</li> </ul>





## USAGE AND MAINTENANCE

### General Rotary Instrument Usage Tips

- For the safety of both user and patient, only qualified dentists should work with dental burs.
- Sterilize all burs before each use.
- Burs should be replaced frequently to avoid using a dull, worn, or damaged bur on a patient. A dull or damaged bur could result in reduced efficiency and possible harm to the patient.
- Never force a bur into the turbine.
- Observe recommended speeds and air pressure. This is particularly true for burs with a large head size or coarse/super coarse diamond grit size because too much speed could create undesirable heat.

#### Maximum RPM

Bur Diameter (1/10 mm)	FG	HP
007-014	450,000	250,000
016-023	300,000	120,000
025-045	120,000	80,000
047-065	80,000	60,000
066-094	60,000	40,000

*Recommended speeds for finishing and polishing instruments can be found in the Finishing and Polishing Instruments product listing section beginning on page 22.*

- Do not put pressure on the bur when in use.
- Don't keep the bur still; constant movement will avoid burning of the bur.
- Do not "extend" the bur (always insert the bur fully into the handpiece chuck).
- Always use the bur with sufficient water coolant.
- Do not use a bur in a worn chuck; doing so might cause bur slippage and/or vibration that can lead to breakage.

## Rotary Instrument Maintenance

### Cleaning

Always wear gloves when handling contaminated instruments.

- Presoak the burs for at least 10 minutes in a disinfection solution designed for dental burs that contains a corrosion inhibitor to minimize the dulling of diamond coating.
- Use a brush to clean the burs thoroughly if needed.
- Rinse several times to remove the disinfection solution.
- Dry the burs and store in a clean and moisture-free environment.

### Cleaning with Ultrasonic

- Burs may be ultrasonically cleaned by inserting them in bur holders.
- A cycle of 5 minutes is recommended, using a general purpose cleaner.
- Rinse several times after cleaning.
- Dry the burs and store in a clean and moisture-free environment.

### Sterilization

Proper sterilization of instruments is extremely important to eliminate the possibility of cross infection of patients and staff with communicable diseases.

- Place the burs in sterilization bags.
- Autoclave the burs for at least 10 minutes at a temperature of 135°C.
- Dry the burs and store in a clean and moisture-free environment.
- Use a dry heat sterilizer at 170°C (340°F) for 1 hour. When used according to the manufacturer's instructions, this will not corrode or dull carbide burs.
- Avoid cold sterilizing solutions as they contain oxidizing agents which may weaken carbide burs.

*Note: It is the responsibility of the user to ensure that sterilization is effective.*

## NUMBERING SYSTEMS

Due to the wide array of different bur sizes and shapes, standard numbering systems are used to make it easier to identify and compare burs. The most common are the U.S. numbering system and the ISO (International Standards Organization) numbering system.

**The U.S. Numbering System**—Most commonly used in the U.S for carbide burs; generally a one to four digit number, depending on the type of bur. E.g., 557FG, 557RA.

**The ISO Numbering System**—Most commonly used for diamond burs in the U.S. (Also for carbides, but not in the U.S.) See our cross-references to match ISO and other numbering systems on pages 20-21.

## THE ISO NUMBERING SYSTEM

A formal International Standards Organization (ISO) coding system has been established to simplify identification and ordering of all burs. An example of the ISO coding system is as follows:

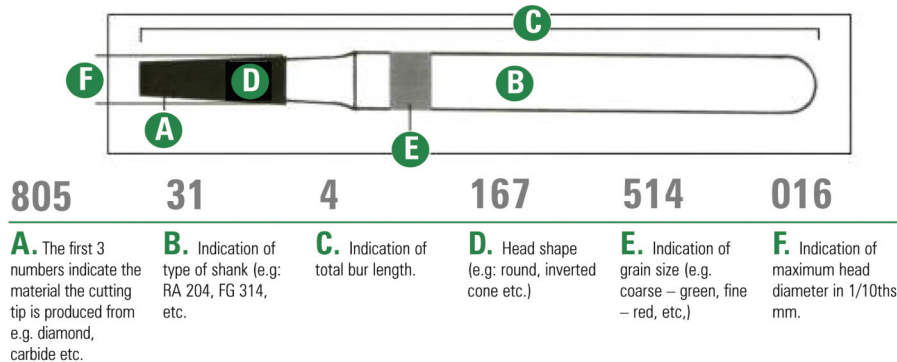









### ISO Bur Shanks

Maximum shank length

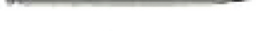
**ISO: Type:**

**Length/ømm**

















<b>104</b> Straight handpiece (HP)		44.5/2.35
<b>202</b> Right angle mini (RA mini)		16/2.35
<b>204</b> Right angle (RA)		22.5/2.35
<b>205</b> Right angle extra long (RA X long)		26.5/2.35
<b>206</b> Right angle surgical (RA surg)		34/2.35
<b>313</b> Friction grip short (FG short)		16.5/1.6
<b>314</b> Friction grip (FG)		19/1.6
<b>315</b> Friction grip extra long (FG X long)		21/1.6
<b>316</b> Friction grip surgical (FG surg)		25.4/1.6

### ISO Diamond Grit Identification

N	= Normal/Medium	ISO code 524
SC	= Super Coarse	ISO code 544
C	= Coarse	ISO code 534
F	= Fine	ISO code 514
SF	= Super Fine	ISO code 504
UF	= Ultra Fine	ISO code 494

### ISO Bur Head Sizes

Maximum diameter of cutting tip

• 009 0.90mm		045 4.5mm
• 010 1.0mm		047 4.7mm
• 012 1.2mm		050 5.0mm
• 014 1.4mm		055 5.5mm
• 016 1.6mm		060 6.0mm
• 018 1.8mm		065 6.5mm
• 021 2.1mm		070 7.0mm
• 023 2.3mm		075 7.5mm
• 025 2.5mm		080 8.0mm
• 027 2.7mm		100 10.0mm
• 029 2.9mm		
• 031 3.1mm		
• 033 3.3mm		
• 035 3.5mm		
• 037 3.7mm		
• 042 4.2mm		



## READING THE CHARTS

### CARBIDES

**U.S. No:** This is the standard number commonly used in the U.S. to indicate the size and shape of the bur.

**Diameter (mm):** This is the diameter of the head, at the widest part of the cutting surface, measured in mm.

**Available Shank Types:** The dots in each column indicate which types of shanks we stock for that particular shape/size. For example, the column under Round #1 burs indicates we carry #1 burs with FG, FG Surg, RA, and HP shanks, but not with FG SS or RA Surg shanks.

### CARBIDE SAMPLE CHART

		ROUND								
U.S. No.		1/4	1/2	1	2	3	4	5	6	8
Diameter (mm)		0.50	0.70	0.80	1.00	1.20	1.40	1.60	1.80	2.30
FG		•	•	•	•	•	•	•	•	•
FG SS			•							
FG Surg.				•	•	•	•	•	•	•
RA		•	•	•	•	•	•	•	•	•
RA Surg.				•	•	•	•	•	•	•
HP		•	•	•	•	•	•	•	•	•

**Available Grits:** The letters in each column indicate the grits we carry for that shape. Super Fine is indicated by a yellow "SF", Fine by a red "F", Medium by a white "M", Coarse by a green "C", and Super Coarse by a black "SC". Our Diamonds will have the matching color ring for easy identification. For example, the column under #807-014 burs indicates that we carry #807-014 burs in F and M grits.

		INVERTED CONE					
Code		805-012	805-016	805-018	807-014	807-016	807-018
Diameter (mm)		1.2	1.6	1.8	1.4	1.6	1.8
Head Length (mm)		1.3	1.4	1.6	3.0	4.0	5.0
Super Fine							
Fine					F		
Medium					M	M	M
Coarse		C	C	C			
Super Coarse							

### FINISHING AND POLISHING INSTRUMENTS

**Description:** This refers to the type of instrument.

**Code:** This is our order number.

**Shank Type:** This refers to the shank style of the instrument: Friction Grip (FG), Right Angle/Latch Type (RA), or Handpiece (HP).

### FINISHING & POLISHING SAMPLE CHART

Pre-Polishers, Coarse				
Description				
Code	COMP-SPC	COMP-PC	COMP-CC	COMP-KEC
Shank	RA	RA	RA	RA

We generally carry FG and RA burs in 10-packs and 100-packs and HP and TF/Specialty burs in 5-packs. Our carbide bur part numbers consist of the U.S. number followed by the type of shank, followed by the pack size. For example, our part number for a #557 bur with a friction grip shank, in a 10-pack, would be 557FG-10.

### DIAMONDS

**Code:** This is our order number. The first three digits indicate the shape (which is the same as the ISO#), and the last three digits indicate the head diameter. For example, item #801-009 is a #801 shape bur with a head diameter of 0.9mm. We carry diamond burs in 5-packs and 100-packs, so a 5 or 100 would be added to the code to indicate the pack size, and a letter would be added to indicate the grit. For example, our part number for a #801 bur with a 0.9mm diameter and medium grit in a 5-pack would be 801-009-M-5.

**Diameter (mm):** This is the diameter of the head at the widest part of the cutting surface, measured in mm.

**Head Length (mm):** This is the length of the cutting head measured in mm.



# carbide BURS

## Features and Benefits of Johnson-Promident Carbide Burs

### FEATURES

#### HIGH QUALITY

*JP carbide burs feature high quality tungsten carbide tips that are brazed onto the neck of a stainless steel shank.*

#### HIGH CONCENTRICITY

*This increased strength and high concentricity of the shank ensures an even tooth preparation.*

#### CAREFUL DESIGN

*JP carbide burs are designed to cut sharper angles with a greater blade contact on the tooth surface.*

#### MADE TO STRICT TOLERANCES

*Complying with international standards, JP burs are manufactured to strict tolerances, eliminating any defects.*

#### HARD WEARING

*JP burs are made from high grade, fine grain tungsten carbide, crafted to resist wear, chipping and breakage.*

#### WIDE RANGE

*The wide range of JP carbide burs accommodate individual preferences and cover a multitude of applications.*

### BENEFITS

#### STRONGER

*This exceeds the international standard required for load bearing, maximizing the strength of the burs and reducing the risk of breakage.*

#### MORE EFFICIENT

*And also means the cut is more efficient, causing less trauma to the tooth and less stress for the patient.*

#### IMPROVED PERFORMANCE

*This gives a fast, smooth, vibration free performance, reducing patient discomfort as well as operative time.*

#### IMPROVES LIFE OF HANDPIECES

*This places less stress on the handpiece and reduces the risk of early chuck failure.*

#### LONG LASTING VALUE FOR MONEY

*This produces a longer lasting, durable bur, which is cost effective and value for money.*

#### ONE STOP SHOP

*This enables you to buy all your requirements from one source.*

Johnson-Promident burs are manufactured under a Quality Assurance system complying with BS EN ISO 9001, BS EN 46001 and the European Directive 93/42/EEC concerning medical devices.

**Johnson-Promident carbide burs were rated as a TOP PRODUCT OF 2012 by an independent evaluation in *Dental Product Shopper* magazine, receiving the highest rating ever given to a carbide bur!**

The overall rating was 4.5 out of 5, with high ratings across all categories, including chatter/vibration, speed, durability, and cutting efficiency. 91% of evaluators stated that they would definitely or probably recommend our burs to colleagues.

Sample comments from evaluators:

*"...This is truly the first carbide bur that cuts like butter to me. [I] loved it."*

*"The chatter/vibration is so much better or non-existent compared to other brands."*

*"For the time I have used the Johnson-Promident burs, no burs have broken, ever."*





# carbide OPERATIVE BURS

ROUND									
U.S. No.	¼	½	1	2	3	4	5	6	8
Diameter (mm)	0.50	0.70	0.80	1.00	1.20	1.40	1.60	1.80	2.30
FG	•	•	•	•	•	•	•	•	•
FG SS		•		•	•	•	•	•	•
FG Surg.			•	•	•	•		•	•
RA		•	•	•	•	•	•	•	•
RA Surg.				•	•	•		•	•
HP	•	•	•	•	•	•	•	•	•

**Round:** For caries excavation, cavity preparation, and root canal access. Smaller sizes often used for single surface cavities, medium sizes often used for interproximal cavities in anterior teeth.

WHEEL	
U.S. No	14
Diameter (mm)	1.20
FG	•

INVERTED CONE								
U.S. No.	33 ½	34	35	36	37	38	39	41
Diameter (mm)	0.70	0.80	1.00	1.20	1.40	1.60	1.80	2.30
FG	•	•	•	•	•	•	•	
FG SS	•	•	•					
FG Surg.		•						
RA		•	•	•		•		
HP		•	•	•	•		•	•

**Inverted Cone:** For producing undercuts in cavity preparations; slightly rounded edges on the blade corners reduce chipping for a smoother cut. Ideal for amalgam removal; may also be used to contour the occlusal anatomy of final restorations and for flattening pulpal and gingival walls.

AMALGAM PREP			
U.S. No.	245	246	256
Diameter (mm)	0.80	1.20	0.80
FG	•	•	•
FG SS	•		

PEAR				
U.S. No.	329	330	331	332
Diameter (mm)	0.60	0.80	1.00	1.20
FG	•	•	•	•
FG SS		•	•	
RA		•		

**Pear:** For contouring the occlusal anatomy, preparing cavities, and removing amalgam. Produces an undercut preparation with round internal line angles.

PEAR (LONG HEAD)	
U.S. No.	331L
Diameter (mm)	1.00
FG	•

FLAT FISSURE PLAIN CUT			
U.S. No.	56	57	58
Diameter (mm)	0.90	1.00	1.20
FG	•	•	•
FG SS	•	•	

FLAT FISSURE PLAIN CUT (LONG HEAD)	
U.S. No.	57L
Diameter (mm)	1.00
FG	•

FLAT FISSURE CROSS CUT				
U.S. No.	556	557	558	560
Diameter (mm)	0.90	1.00	1.20	1.60
FG	•	•	•	•
FG SS	•	•		
FG Surg.	•	•	•	
RA		•	•	
RA Surg.		•	•	
HP	•	•	•	•

FLAT FISSURE CROSS CUT (LONG HEAD)			
U.S. No.	556L	557L	558L
Diameter (mm)	0.90	1.00	1.20
FG	•	•	•

**Flat Fissure Plain Cut/Flat Fissure Cross Cut:** For producing preparations with straight parallel sides and flat floors, gaining access to carious dentin, establishing preparation form, and creating retentive locks. Cross cut burs have more cutting edges.

**FG:** Friction Grip  
**SS:** Short Shank  
**Surg:** Surgical Length  
**RA:** Right Angle (Latch Type)  
**HP:** Handpiece

FG, SS, SURG, RA available in 10 packs and 100 packs and HP available in 5 packs and 100 packs

# carbide OPERATIVE BURS

## TAPER FISSURE PLAIN CUT

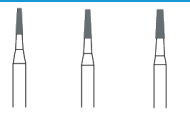

U.S. No.	169	170	171
Diameter (mm)	0.90	1.00	1.20
FG	•	•	•
HP		•	•

## TAPER FISSURE PLAIN CUT (LONG HEAD)



U.S. No.	169L	170L	171L
Diameter (mm)	0.90	1.00	1.20
FG	•	•	•

**Taper Fissure Plain Cut/Taper Fissure Cross Cut:** For producing a preparation with tapered, divergent walls and a flat floor. Also used for inlay/onlay preparation and to section teeth and cut bone. Cross cut burs have more cutting edges.

## TAPER FISSURE CROSS CUT

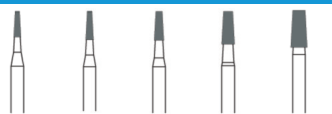

U.S. No.	699	700	701	702	703
Diameter (mm)	0.90	1.00	1.20	1.60	2.10
FG	•	•	•	•	•
FG SS	•	•			
FG Surg.		•	•	•	•
RA		•	•	•	•
HP	•	•	•	•	•

## TAPER FISSURE CROSS CUT (LONG HEAD)



U.S. No.	699L	700L	701L
Diameter (mm)	0.90	1.00	1.20
FG	•	•	•

## DOMED FISSURE PLAIN CUT

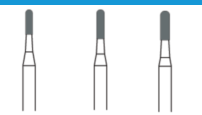

U.S. No.	1156	1157	1158
Diameter (mm)	0.90	1.00	1.20
FG	•	•	•
FG SS		•	

## DOMED FISSURE CROSS CUT



U.S. No.	1556	1557	1558
Diameter (mm)	0.90	1.00	1.20
FG	•	•	•
FG Surg.		•	•
HP	•	•	•

**Domed Fissure Plain Cut/Domed Fissure Cross Cut:** For producing a preparation with straight, parallel, or minimally divergent walls with round internal line angles. Also used to gain access to carious dentin, establish preparation form, and create retentive locks. Cross cut burs have more cutting edges.

## DOMED TAPER FISSURE PLAIN CUT



U.S. No.	1170	1171	1172
Diameter (mm)	1.00	1.20	1.60
FG	•	•	•

## DOMED TAPER FISSURE CROSS CUT

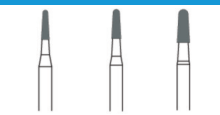

U.S. No.	1700	1701	1702
Diameter (mm)	1.00	1.20	1.60
FG	•	•	•
FG Surg.			•

**Domed Taper Fissure Plain Cut/Domed Taper Fissure Cross Cut:** Used to create preparations with tapered, divergent walls and round internal line angles, to section teeth and cut bone, and to quickly shape primary anatomy in restorative material. Cross cut burs have more cutting edges.

## END CUTTING BURS



U.S. No.	957
Diameter (mm)	1.00
FG	•

**End Cutting:** Used to produce a flat preparation floor, refine preparations, and to mark the depth of bone reduction in crown lengthening. Help reduce any possibility of impacting the surface of the adjacent tooth with the cutting surface of a bur.

**FG:** Friction Grip  
**SS:** Short Shank  
**Surg:** Surgical Length  
**RA:** Right Angle (Latch Type)  
**HP:** Handpiece

FG, SS, SURG, RA available in 10 packs and 100 packs and HP available in 5 packs and 100 packs





# carbide ORTHODONTIC, SURGICAL, AND SPECIALTY BURS

## ORTHODONTIC BURS



U.S. No.	118S	118L	218	48L
Diameter (mm)	1.60	1.60	1.60	1.20
FG	•	•	•	•

### Orthodontic Burs

Ideal for adhesive removal

#### Also Popular for Use In Orthodontics

- FG169L
- FG1172
- TF7404
- TF7406
- TF7408
- TF7901
- TF7903

## ESTHETIC FINISHING BURS



U.S. No.	EF3	EF4	EF6	EF9	OF1	OF2	OF3
10 blades							
Diameter (mm)	0.80	1.00	1.40	1.40	2.30	0.90	0.70
10 blades	•	•	•	•			
12 blades					•	•	•

### Esthetic Finishing Burs

Ensure a controlled cut for a smoother finish and reduce trauma to the gingival and adjacent tooth structure for better patient comfort.

**EF Series:** For anterior and posterior gingival and subgingival contouring or margins.

**OF Series:** For contouring and placement of occlusal grooves.

## METAL CUTTING BURS



U.S. No.	331/1931	1558/1958	557/2057
Diameter (mm)	1.0	1.2	1.0
JP #	JP1	JP2	JP557/2057

### Metal Cutting

Provide maximum cutting efficiency

JP 1: Ideal for removing PFM crown and non-precious metal.

JP 2: Ideal for quick titanium abutment adjustments without the sparking associated with diamonds and for removing old restorations in secondary decay.

## SURGICAL BUR 151



U.S. No.	151	151L
Diameter (mm)	1.60	1.60
FG	•	•

### Surgical Bur 151

Has six spiral blades for removal of debris, sectioning an impacted wisdom tooth before extraction, separating roots, and removal of a broken root stump.

## LINDEMANN BURS



U.S. No.	161	162
Diameter (mm)	1.60	1.60
FG SURG.	•	•





### Lindemann Burs

Has four blades for aggressive cutting of hard tissue or bone structure.







Ortho, Esthetic Finishing, Surgical, and Lindemann Burs available in 5 packs.  
Metal cutting burs available in 10 packs and 100 packs





# carbide TRIMMING AND FINISHING BURS



ROUND			
			
U.S. No. 12 flutes	7004	7006	7008
U.S. No. 30 flutes		9006	9008
Diameter (mm)	1.40	1.80	2.30
TF 12 flutes	•	•	•
FF 30 flutes		•	•

**Round:** For contouring and finishing restorations, root planning, bone contouring and smoothing.

FLAME			
			
U.S. No. 12 flutes	7104	7106	7108
Diameter (mm)	1.40	1.80	2.30
TF 12 flutes	•	•	•





**Twelve bladed finishing burs (7000 series)** provide a smooth finish on composite, amalgam, enamel, dentin, ortho debonding, and other dental materials. Best for controlled contouring and finishing.

LONG TAPER			
			
U.S. No.	7204	7205	7206
Diameter (mm)	1.40	1.60	1.80
TF 12 flutes	•	•	•







PEAR	
	
U.S. No.	7303
Diameter (mm)	1.20
TF 12 flutes	•



**Pear:** For refinement of preparations and contouring and finishing of restorations.



**Thirty bladed finishing burs (9000 series)** will eliminate most surface striations and, because the thirty blades remove less material per revolution, are recommended for use before abrasive polishing. Designed to reduce the "shiny dull" phenomenon and save additional polishing time. Best for final surface refinement, satin polishing, and use on ceramics because they produce a less aggressive cut.

EGG			
			
U.S. No. 12 flutes	7404	7406	7408
U.S. No. 30 flutes		9406	
Diameter (mm)	1.40	1.80	2.30
TF 12 flutes	•	•	•
FF 30 flutes		•	•

**Egg:** For contouring and finishing occlusal and lingual surfaces.

TAPER POINTED						
						
U.S. No. 12 flutes	7114	7611	7612	7214	7613	7714
U.S. No. 30 flutes				9214		9714
Diameter (mm)	0.90	0.10	0.14	0.10	1.40	1.60
TF 12 flutes	•	•	•	•	•	•
FF 30 flutes						•

TAPER FLAT END	
	
U.S. No. 30 flutes	9713
Diameter (mm)	1.20
FF 30 flutes	•





TAPER ROUND END		
		
U.S. No. 12 flutes	7642	7664
U.S. No. 30 flutes	9642	
Diameter (mm)	1.00	1.40
TF 12 flutes	•	•
FF 30 flutes	•	





**TF:** Trimming & Finishing  
**FF:** Fine Finishing

Available in 5 packs







# carbide BURS

BULLET			
			
U.S. No. 12 flutes	7801	7802	7803
U.S. No. 30 flutes			9803
Diameter (mm)	0.90	1.00	1.20
TF 12 flutes	•	•	•
FF 30 flutes			•

NEEDLE				
				
U.S. No. 12 flutes	7901	7902	7903	
U.S. No. 30 flutes			9903	9904
Diameter (mm)	0.90	1.00	1.20	1.40
TF 12 flutes	•	•	•	
FF 30 flutes			•	•

**Needle:** For contouring and finishing interproximal margins, occlusal margins, facial surfaces, and cavosurface margins.

INTERPROXIMAL	
	
U.S. No. 30 flutes	9103
Diameter (mm)	1.20
FF 30 flutes	•

LONG FLAME	
	
U.S. No.	48L
Diameter (mm)	1.20
FF 12 flutes	•



**TF: Trimming & Finishing**  
**FF: Fine Finishing**

Available in 5 packs

# diamond BURS

## Features and Benefits of Johnson-Promident Diamond Burs

Johnson-Promident diamond burs are available in a wide range of sizes and grits, for every procedure. They are manufactured to the highest international standards, using the best quality materials. Each bur is microscopically tested to ensure that it is 100% controlled.

### FEATURES

#### BETTER PLATING PROCESS

*Our plating method ensures that the diamond surface is homogenized, with no "bald" areas and equal distribution of bond matrix and grit.*

#### BETTER MATERIALS

*Top quality materials. Swiss-made steel blanks, hardened, turned, and ground. Specially-made mix of natural diamond grits.*

#### BETTER SELECTION

*Over 100 shapes and sizes in a wide range of grits*

#### GUARANTEED QUALITY

*Manufactured under the highest international standards, with each bur microscopically tested to ensure 100% control.*

### BENEFITS

- *Minimal pressure required on the turbine*
- *Prepared tooth surface is homogenous*
- *Concentric, balanced bur with long-lasting cutting ability*
- *Diamond sharpness is maximized*

- *Maximum precision and minimum vibration*
- *Superior cutting efficiency and long instrument life*
- *Rapid, smooth, and comfortable cutting*

- *Johnson-Promident is your one-stop shop for diamonds*

*Worry-free*







*Call for pricing and availability of logic sets and premium packaging*



















# diamond BURS





ROUND						
						
Code	801-009	801-012	801-014	801-016	801-018	801-022
Diameter (mm)	0.9	1.2	1.4	1.6	1.8	2.2
Head Length (mm)	0.9	1.2	1.4	1.6	1.8	2.2
Super Fine						
Fine						
Medium	Ⓜ					
Coarse		C	C	C	C	C
Super Coarse						



INVERTED CONE						
						
Code	805-012	805-016	805-018	807-014	807-016	807-018
Diameter (mm)	1.2	1.6	1.8	1.4	1.6	1.8
Head Length (mm)	1.3	1.4	1.6	3.0	4.0	5.0
Super Fine						
Fine				F		
Medium				Ⓜ	Ⓜ	Ⓜ
Coarse	C	C	C			
Super Coarse						

DOUBLE INVERTED CONE			
			
Code	806-012	806-014	813-018
Diameter (mm)	1.2	1.4	1.8
Head Length (mm)	3.0	2.0	2.1
Super Fine			
Fine			
Medium		Ⓜ	Ⓜ
Coarse	C		
Super Coarse			

BARREL		
		
Code	811-033	811-037
Diameter (mm)	3.3	3.7
Head Length (mm)	5.5	5.5
Super Fine		
Fine		
Medium		
Coarse	C	C
Super Coarse		SC

PEAR	
	
Code	830L-012
Diameter (mm)	1.2
Head Length (mm)	3.9
Super Fine	
Fine	
Medium	Ⓜ
Coarse	
Super Coarse	

WHEEL	
	
Code	818-030
Diameter (mm)	3.0
Head Length (mm)	0.8
Super Fine	
Fine	
Medium	Ⓜ
Coarse	
Super Coarse	

ROUND WHEEL		
		
Code	909-037	909-040
Diameter (mm)	3.7	4.0
Head Length (mm)	1.0	1.3
Super Fine		
Fine		
Medium	Ⓜ	
Coarse	C	C
Super Coarse		

SF: Super Fine

F: Fine

Ⓜ: Medium

C: Coarse

SC: Super Coarse

Diamond burs available in 5 packs and 100 packs

# diamond BURS



GROSS REDUCTION				
<b>Code</b>	<b>651-016</b>	<b>652-018</b>	<b>654-016</b>	<b>655-018</b>
Diameter (mm)	1.6	1.8	1.6	1.8
Head Length (mm)	6.0	8.0	6.0	8.0
Super Fine				
Fine				
Medium				
Coarse	<b>C</b>	<b>C</b>	<b>C</b>	<b>C</b>
Super Coarse				



EGG/FOOTBALL							
<b>Code</b>	<b>368-016</b>	<b>368-018</b>	<b>368-023</b>	<b>369-023</b>	<b>379-016</b>	<b>379-018</b>	<b>379-023</b>
Diameter (mm)	1.6	1.8	2.3	2.3	1.6	1.8	2.3
Head Length (mm)	3.3	4.5	5.3	5.1	3.4	3.6	4.4
Super Fine		<b>SF</b>	<b>SF</b>				<b>SF</b>
Fine	<b>F</b>	<b>F</b>	<b>F</b>	<b>F</b>	<b>F</b>	<b>F</b>	<b>F</b>
Medium		<b>M</b>	<b>M</b>			<b>M</b>	<b>M</b>
Coarse		<b>C</b>	<b>C</b>	<b>C</b>		<b>C</b>	<b>C</b>
Super Coarse			<b>SC</b>				



INTER PROXIMAL	
<b>Code</b>	<b>392-016</b>
Diameter (mm)	1.6
Head Length (mm)	5.0
Super Fine	<b>SF</b>
Fine	<b>F</b>
Medium	
Coarse	<b>C</b>
Super Coarse	



FLAT END CYLINDER											
<b>Code</b>	<b>835-008</b>	<b>835-010</b>	<b>835-012</b>	<b>835-014</b>	<b>836-012</b>	<b>836-014</b>	<b>837-010</b>	<b>837-012</b>	<b>837-014</b>	<b>837-016</b>	<b>837-018</b>
Diameter (mm)	0.8	1.0	1.2	1.4	1.2	1.4	1.0	1.2	1.4	1.6	1.8
Head Length (mm)	4.0	4.0	4.0	4.0	5.6	6.0	8.0	8.0	8.0	8.0	8.0
Super Fine											
Fine		<b>F</b>									
Medium	<b>M</b>	<b>M</b>						<b>M</b>	<b>M</b>	<b>M</b>	
Coarse		<b>C</b>	<b>C</b>	<b>C</b>	<b>C</b>	<b>C</b>	<b>C</b>	<b>C</b>	<b>C</b>	<b>C</b>	<b>C</b>
Super Coarse											



CYLINDER ROUNDED SHOULDER			
<b>Code</b>	<b>836KR-014</b>	<b>837KR-012</b>	<b>837KR-016</b>
Diameter (mm)	1.4	1.2	1.6
Head Length (mm)	6.0	8.0	8.0
Super Fine			
Fine			
Medium			
Coarse	<b>C</b>	<b>C</b>	<b>C</b>
Super Coarse			



ROUND END CYLINDER		
<b>Code</b>	<b>881-014</b>	<b>881-016</b>
Diameter (mm)	1.4	1.6
Head Length (mm)	8.0	8.0
Super Fine		
Fine		
Medium		<b>M</b>
Coarse	<b>C</b>	<b>C</b>
Super Coarse		

- SF: Super Fine**
- F: Fine**
- M: Medium**
- C: Coarse**
- SC: Super Coarse**

Diamond burs available in 5 packs and 100 packs

# diamond BURS



FLAT END TAPER										
<b>Code</b>	846-012	846-018	847-014	847-016	847-018	847-019	848-012	848-016	848-018	
Diameter (mm)	1.2	1.8	1.4	1.6	1.8	1.9	1.2	1.6	1.8	
Head Length (mm)	6.0	7.0	8.0	8.0	8.0	8.0	10.0	10.0	10.0	
Super Fine										
Fine										
Medium				M		M		M		
Coarse	C	C	C	C	C	C	C	C	C	C
Super Coarse										



TAPER ROUNDED SHOULDER					
<b>Code</b>	845KR-018	845KR-025	846KR-016	847KR-016	847KR-018
Diameter (mm)	1.8	2.5	1.6	1.6	1.8
Head Length (mm)	4.0	4.0	6.0	8.0	8.0
Super Fine					
Fine		F			
Medium		M	M	M	M
Coarse	C	C	C	C	C
Super Coarse					



ROUND END TAPER												
<b>Code</b>	850-012	850-014	850-016	850-018	855-012	855-014	855-018	855-025	856-010	856-012	856-014	856-016
Diameter (mm)	1.2	1.4	1.6	1.8	1.2	1.4	1.8	2.5	1.0	1.2	1.4	1.6
Head Length (mm)	10.0	10.0	10.0	10.0	6.3	6.3	6.4	7.0	8.0	8.0	8.0	8.0
Super Fine												
Fine			F	F								F
Medium				M	M	M						M
Coarse	C	C	C	C		C	C	C	C	C	C	C
Super Coarse												SC



ROUND END TAPER (CONTINUED)					
<b>Code</b>	856-018	856-025	856L-016	856L-018	856L-020
Diameter (mm)	1.8	2.5	1.6	1.8	2.0
Head Length (mm)	9.0	8.0	9.0	9.0	9.0
Super Fine					
Fine	F				
Medium	M				
Coarse	C	C	C	C	C
Super Coarse	SC				

**SF: Super Fine**

**F: Fine**

**M: Medium**

**C: Coarse**

**SC: Super Coarse**

*Diamond burs available in 5 packs and 100 packs*

# diamond BURS



NEEDLE									
Code	858-010	858-012	858-014	858-016	859-010	859-012	859-014	859-016	859L-016
Diameter (mm)	1.0	1.2	1.4	1.6	1.0	1.2	1.4	1.6	1.6
Head Length (mm)	8.0	8.0	8.0	8.0	10.0	10.0	10.0	10.0	10.5
Super Fine			SF				SF	SF	
Fine	F				F		F	F	F
Medium		M	M	M	M		M	M	M
Coarse			C			C	C	C	
Super Coarse									



FLAME									
Code	390-018	860-010	861-014	862-010	862-012	862-014	862-018	863-010	863-012
Diameter (mm)	1.8	1.0	1.4	1.0	1.2	1.4	1.8	1.0	1.2
Head Length (mm)	3.0	4.0	6.0	8.0	8.0	8.0	8.0	10	10
Super Fine			SF		SF	SF			
Fine	F			F	F	F		F	F
Medium		M			M				M
Coarse				C	C	C	C		C
Super Coarse									



GINGIVAL CURETTAGE				
Code	878K-014	878K-016	878K-018	879K-018
Diameter (mm)	1.4	1.6	1.8	1.8
Head Length (mm)	8.0	8.0	8.0	9.5
Super Fine				
Fine				
Medium				M
Coarse	C	C	C	
Super Coarse				



TORPEDO CYLINDER		
Code	878-012	878-014
Diameter (mm)	1.2	1.4
Head Length (mm)	8.0	8.0
Super Fine		
Fine		
Medium		M
Coarse		C
Super Coarse		



POINTED CYLINDER				
Code	885-010	885-012	886-012	886-016
Diameter (mm)	1.0	1.2	1.2	1.6
Head Length (mm)	8.0	8.0	10.0	10.0
Super Fine				
Fine				
Medium		M	M	
Coarse	C	C	C	C
Super Coarse				



SEPARATION		
Code	889-008	889-010
Diameter (mm)	0.8	1.0
Head Length (mm)	3.0	4.0
Super Fine		
Fine	F	F
Medium		
Coarse		
Super Coarse		



- SF: Super Fine
- F: Fine
- M: Medium
- C: Coarse
- SC: Super Coarse

Diamond burs available in 5 packs and 100 packs



# DIAMOND BURS CROSS-REFERENCE CHART

Johnson-Promident	Grit	Brasseler USA	Meisenger	Axis	SS White	Midwest	Premier	Neo
<b>Round</b>								
801-009	M	004159U0	801-009	M801-009	-	471008	-	-
801-012	M	004161U0	801-012	M801-012	-	471010	-	0112M
801-012	C	004781U0	801G-012	C801-012	-	471019	115C	-
801-014	M	004162U0	801-014	M801-014	91002	471011	-	-
801-014	C	004782U0	801G-014	C801-014	-	471020	-	-
801-016	M	004163U0	801-016	M801-016	-	471012	-	0116M
801-016	C	004783U0	801G-016	C801-016	-	471021	120C	0116C
801-018	M	004164U0	801-018	M801-018	91003	471013	-	0118M
801-018	C	004784U0	801G-018	C801-018	91004	471022	125C	0118C
801-022	M	-	-	-	-	-	-	-
801-022	C	-	-	-	-	-	-	-
<b>Inverted Cone</b>								
805-012	C	004793U0	805G-012	C805-012	91010	471050	310.1C	-
805-016	C	-	805G-016	C805-016	91012	-	315.1.75C	0316C
805-018	C	-	805G-018	-	-	-	318.5C	-
807-014	F	-	-	-	-	-	-	-
807-014	M	-	807-014	-	-	-	-	-
807-016	M	004236U0	807-016	M807-016	-	471055	-	-
807-018	M	004237U0	807-018	C807-018	-	471056	-	-
<b>Double Inverted Cone</b>								
806-012	C	004797U0	806G-012	C806-012	91016	-	390.3C	-
806-014	M	004225U0	806-014	M806-014	-	-	-	-
813-018	M	004258U0	-	-	-	471069	1250M	-
<b>Barrel</b>								
811-033	C	017277U0	811G-033	C811-033	-	471060	230C	2133C
811-037	C	017278U0	-	C811-037	-	471061	234C	2137C
811-037	SC	012925U0	-	SC811-037	-	471063	-	-
<b>Pear</b>								
830L-012	M	004954U0	-	M830L-012	-	-	-	-
<b>Wheel</b>								
818-030	M	-	-	-	-	-	-	-
<b>Round Wheel</b>								
909-037	M	-	-	M909-037	-	-	-	-
909-037	C	-	-	C909-037	-	-	860C	2035C
909-040	C	004906U0	909G-040	C909-040	471383	471383	862C	2040C
<b>Gross Reduction</b>								
651-016	C	-	-	-	-	-	-	-
652-018	C	-	-	-	-	-	-	-
654-016	C	-	-	-	-	-	-	-
655-014	C	-	-	-	-	-	-	-
655-018	C	-	-	-	-	383911	5T.8	2218C
<b>Egg/Football</b>								
368-016	F	004959U0	-	F368-016	-	471409	-	1916F
368-018	SF	-	-	SF368-018	-	-	-	-
368-018	F	-	-	F368-018	-	-	-	-
368-018	M	-	-	M368-018	-	-	-	-
368-018	C	-	-	C368-018	-	-	290.4C	-
368-023	SF	005256U0	-	SF368-023	-	471414	-	3923VF
368-023	F	004960U0	-	F368-023	91143	471415	-	1923F
368-023	M	004085U0	-	M368-023	-	471416	-	1923M
368-023	C	004768U0	-	C368-023	-	471417	285.5C	1923C
368-023	SC	015169U0	-	SC368-023	-	471418	-	-
369-023	F	-	-	-	-	-	-	-
369-023	C	-	-	-	-	-	-	-
379-016	F	004965U0	-	F379-016	-	471422	-	-
379-018	F	017165U0	-	F379-018	-	471423	-	1908F
379-018	M	004092U0	-	M379-018	-	471424	-	-
379-018	C	-	-	C379-018	-	-	290.4C	1908C
379-023	SF	005258U0	-	SF379-023	-	471399	-	3900VF
379-023	F	004967U0	-	F379-023	-	471400	-	1900F
379-023	M	004093U0	-	M379-023	-	471427	-	1900M
379-023	C	013889U0	-	C379-023	91142	471428	287.4C	1900C
<b>Interproximal</b>								
392-016	SF	005281U0	-	SF392-016	-	471447	-	-
392-016	F	004969U0	-	F392-016	-	471448	203.5F	1416F
392-016	C	-	-	-	-	-	-	-
<b>Flat End Cylinder</b>								
835-008	M	004343U0	835-008	-	-	-	-	-
835-010	F	005020U0	835F-010	F835-010	-	-	-	-
835-010	M	004345U0	835-010	M835-010	-	-	-	0710M
835-010	C	004809U0	835G-010	C835-010	91031	-	513.4C	0710C
835-012	C	004810U0	835G-012	C835-012	91032	-	514.3C	0712C
835-014	C	004811U0	835G-014	C835-014	-	-	-	-
836-012	C	004813U0	-	C836-012	91033	471075	514.5C	-
836-014	C	004814U0	836G-014	C836-014	91034	471076	520.4C	-
837-010	C	-	-	C837-010	-	-	514.7C	-
837-012	M	004368U0	837-012	M837-012	-	471086	-	-
837-012	C	004818U0	837G-012	C837-012	91035	471089	515.7C	0712.7C
837-014	M	004369U0	837-014	M837-014	-	471087	-	-
837-014	C	004819U0	837G-014	C837-014	91036	471090	515.8C	-
837-016	M	004370U0	837-016	M837-016	-	471088	-	-
837-016	C	004820U0	837G-016	C837-016	91037	471091	516.7C	0716.8C
837-018	C	-	-	-	-	-	-	-
<b>Cylinder Rounded Shoulder</b>								
836KR-014	C	-	-	C836KR-014	-	-	521.6C/550.8C	-
837KR-012	C	-	-	C837KR-012	-	-	-	-
837KR-016	C	018305U0	-	C837KR-016	-	471098	-	-
<b>Round End Cylinder</b>								
881-014	C	012155U0	881G-014	C881-014	91043	-	550.8C	1214.8C
881-016	M	013559U0	881-016	-	-	-	-	-
881-016	C	-	881G-016	C881-016	91044	-	-	-
<b>Flat End Taper</b>								
846-012	C	004828U0	846G-012	C846-012	-	-	721.6C	-
846-018	C	-	-	-	-	-	701.7C	-
847-014	C	004836U0	847G-014	C847-014	91055	471128	702.8C	0914.8C
847-016	M	004418U0	847-016	M847-016	-	471125	-	0916.8M
847-016	C	004837U0	847G-016	C847-016	91056	471129	722.8C	0916.8C
847-018	C	004838U0	847G-018	C847-018	91057	471130	703.8C	0918.8C
847-019	M	-	-	-	-	-	-	-
847-019	C	-	-	-	-	-	-	-
848-012	C	-	848G-012	C848-012	-	-	721.10C	-
848-016	M	004425U0	848-016	M848-016	-	471154	722.10M	0916.10M
848-016	C	004842U0	848G-016	C848-016	91058	471158	722.10C	0916.10C
848-018	C	004843U0	848G-018	C848-018	91059	471159	700.11C	0918.10C

# DIAMOND BURS CROSS-REFERENCE CHART

Johnson-Promident	Grit	Brasseler USA	Meisenger	Axis	SS White	Midwest	Premier	Neo
<b>Taper Rounded Shoulder</b>								
845KR-018	C	020928U0	–	C845KR-018	–	471109	708.4KRC	0818.4C
845KR-025	F	015509U0	–	F845KR-025	–	471105	–	–
845KR-025	M	015512U0	–	M845KR-025	–	471108	–	2525M
845KR-025	C	020932U0	–	C845KR-025	–	471110	712.3KRC	–
846KR-016	M	014883U0	–	M846KR-016	–	471116	–	–
846KR-016	C	–	–	C846KR-016	–	–	722.8CKR	–
847KR-016	M	014888U0	847KR-016	M847KR-016	–	471144	–	0816.8M
847KR-016	C	015167U0	–	C847KR-016	–	471145	722.8KRC	0816.8C
847KR-018	M	018106U0	–	M847KR-018	–	–	–	–
847KR-018	C	016078U0	–	C847KR-018	–	471146	703.8KRC	0818.8C
<b>Round End Taper</b>								
850-012	C	–	850G-012	C850-012	–	–	781.10C	1112.10C
850-014	C	004850U0	850G-014	C850-014	–	471174	781.10C	1114.10C
850-016	F	015979U0	850F-016	F850-016	–	471168	–	1116.10F
850-016	C	004851U0	850G-016	C850-016	–	471175	782.10C	1116.10C
850-018	F	–	850F-018	F850-018	–	–	–	–
850-018	M	004450U0	850-018	M850-018	–	471172	–	–
850-018	C	004852U0	850G-018	C850-018	–	471176	770.10C	–
855-012	M	004478U0	855-012	M855-012	–	471189	–	–
855-014	M	004479U0	–	M855-014	–	471190	–	–
855-014	C	–	–	C855-014	91067	–	799.6.5C	–
855-018	C	–	–	–	–	–	767.7C	–
855-025	C	–	–	C855-025	–	–	785.7C	–
856-010	C	–	–	–	–	–	777.8C	–
856-012	C	004862U0	–	C856-012	–	471207	781.8C	1112.7C
856-014	C	004863U0	–	C856-014	–	471208	782.6C	1114.8C
856-016	F	005041U0	–	F856-016	91116	471198	–	1116.8F
856-016	M	004488U0	–	M856-016	91068	471203	–	1116.8M
856-016	C	004864U0	–	C856-016	91069	471209	782.8C	1116.8C
856-016	SC	004745U0	–	SC856-016	–	471215	–	–
856-018	F	001734U0	–	F856-018	91117	471199	–	1118.7F
856-018	M	004489U0	–	M856-018	–	471204	–	–
856-018	C	004865U0	–	C856-018	91070	471210	770.8C	1118.7C
856-018	SC	004746U0	–	SC856-018	–	471216	–	–
856-025	C	004866U0	–	C856-025	–	471212	790.8C	2424C
856L-016	C	005304U0	–	C856L-016	–	471241	770.9C	–
856L-018	C	005305U0	–	C856L-018	–	471242	770.10C	1118.9C
856L-020	C	005306U0	–	C856L-020	–	471243	–	–
<b>Needle</b>								
858-010	F	–	858F-010	F858-010	–	–	–	–
858-012	M	–	–	M858-012	–	–	–	–
858-014	SF	005372U0	858C-014	SF858-014	–	471249	–	3314.8VF
858-014	M	004495U0	858-014	M858-014	91071	471251	–	1314.8M
858-014	C	004868U0	858G-014	C858-014	91072	471253	207.7C	1314.8C
858-016	M	004496U0	858-016	–	91073	471252	–	–
859-010	F	005046U0	859F-010	F859-010	–	–	797.11F	13212.11F
859-010	M	004499U0	859-010	M859-010	–	–	797.11M	–
859-012	C	–	–	C859-012	–	–	–	1312.11C
859-014	SF	–	859C-014	SF859-014	–	–	–	3314.10VF
859-014	F	–	859F-014	F859-014	–	–	–	1314.10F
859-014	M	–	859-014	M859-014	–	–	–	1314.10M
859-014	C	–	859G-014	C859-014	–	–	608.9C	1314.10C
859-016	SF	–	859C-016	SF859-016	91127	–	–	–
859-016	F	–	859F-016	F859-016	91119	–	–	–
859-016	M	–	859-016	M859-016	–	–	–	–
859-016	C	–	859G-016	C859-016	91075	–	262.10C	–
<b>Long Needle</b>								
859L-016	F	–	–	F859L-016	–	–	–	–
859L-016	M	–	859L-016	M859L-016	–	–	–	–
<b>Flame</b>								
390-018	F	–	–	–	–	–	–	–
860-010	M	004510U0	860-010	–	91078	–	–	–
861-014	SF	–	861C-014	–	–	–	–	–
862-010	F	011994U0	862F-010	F862-010	–	471262	–	1510.8F
862-010	C	–	862G-010	C862-010	–	–	261.8C	1510.8C
862-012	SF	005374U0	862C-012	SF862-012	91128	471260	–	3512.8VF
862-012	F	005053U0	862F-012	F862-012	91121	471263	–	1512.8F
862-012	M	004520U0	862-012	M862-012	–	471267	–	1512.8M
862-012	C	004878U0	862G-012	C862-012	91083	471271	261.8C	1512.8C
862-014	SF	–	862C-014	SF862-014	–	–	–	–
862-014	F	015568U0	862F-014	F862-014	–	471264	–	–
862-014	C	004879U0	862G-014	C862-014	91084	471272	260.8C	1514.8C
862-018	C	–	–	C862-018	–	–	262.8C	–
863-010	F	–	–	F863-010	–	–	–	–
863-012	F	005056U0	863F-012	F863-012	–	–	–	1512.10F
863-012	M	004529U0	863-012	M863-012	–	–	797.11M	1512.10M
863-012	C	004883U0	863G-012	C863-012	91086	–	–	1512.10C
863-016	M	004530U0	863-016	M863-016	–	–	–	–
863-016	C	004884U0	863G-016	C863-016	91088	–	253.10C	–
<b>Gingival Curettage</b>								
878K-014	C	005316U0	–	C878K-014	–	471325	764.8C	1714.8C
878K-016	C	005317U0	–	C878K-016	–	471326	253.8C	1716.8C
878K-018	C	005318U0	–	C878K-018	–	471327	–	1718.8C
879K-018	M	005005U0	–	M879K-018	91101	–	–	–
<b>Torpedo Cylinder</b>								
878-012	M	004560U0	878-012	M878-012	–	471304	–	–
878-012	C	004890U0	878G-012	C878-012	–	471307	511.8C	1800.8C
878-014	C	004891U0	878G-014	C878-014	–	471308	244.10C	1804.8C
<b>Pointed Cylinder</b>								
885-010	C	–	–	–	91104	–	248.8C	–
885-012	M	004578U0	885-012	M885-012	–	471350	–	1812.8M
885-012	C	004899U0	885G-012	C885-012	91105	471352	251.8C	1812.8C
886-012	M	012181U0	886-012	M886-012	–	–	–	1812.10M
886-012	C	–	886G-012	C886-012	–	–	250.9C	1812.10C
886-016	C	004901U0	886G-016	C886-016	91106	–	–	–
<b>Separation</b>								
889-008	F	–	–	–	–	–	–	–
889-010	F	005087U0	–	F889-010	–	471365	–	–

# finishing and polishing INSTRUMENTS

## Finishing and Polishing Instruments Usage Guide

PROCEDURE	MATERIAL					
	COMPOSITE	PORCELAIN/ CERAMIC	GOLD/ AMALGAM	ACRYLIC	ENAMEL	ZIRCONIA
<i>Grinding/ Finishing Abrasives</i>	Green/White Stones	<ul style="list-style-type: none"> <li>• Diamond Abrasives</li> <li>• Green and White Stones</li> </ul>	Green Stones	White Stones	White Stones	Diamond Abrasives
<i>Polishing</i>	<ul style="list-style-type: none"> <li>• Composite Discs/Strips</li> <li>• Single and Two-Step Composite Polishers</li> </ul>	<ul style="list-style-type: none"> <li>• Porcelain Polishers</li> <li>• Diamond Strips</li> </ul>	Amalgam/ Gold Polishers	Acrylic Polishers	<ul style="list-style-type: none"> <li>• Composite Discs/Strips</li> <li>• Single and Two-Step Composite Polishers</li> </ul>	<ul style="list-style-type: none"> <li>• Diamond Porcelain Polishers</li> <li>• Diamond Strips</li> </ul>



### Diamond Strips

Fast-cutting diamond strips. Stainless steel with diamond grit. Thin and flexible; will not stretch or break. Fully autoclavable. Diamond coating is ideal for finishing enamel and restorative materials. 6" long and gapped for easy interproximal insertion.

#### Standard

Description	Super Fine	Fine	Medium
Code	FS4-SF	FS4-F	FS4-M

10 per package



#### Perforated

Perforated design provides improved visibility, more flexibility, and total control in reduction, shaping, and contouring.

Description	Super Fine	Fine	Medium
Code	FS4P-SF	FS4P-F	FS4P-M

10 per package

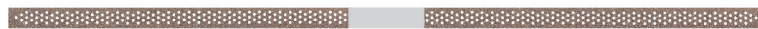









# finishing and polishing INSTRUMENTS

*Compare and Save!*

## Composite Discs and Strips, 3M Sof-Lex-Type

Easy to use and ideal for all composites. Produce surface smoothness and visual gloss for more natural and life-like results. Color-coded to simplify your polishing procedures. Made of aluminum oxide on a flexible ultra-thin mylar backing, allowing the disc to conform to the contours of the teeth.

**Disc Refills\*** (maximum RPM 20,000)

	SIZE	GROSS REDUCTION	CONTOUR	FINISH	POLISH
Description	<b>3/8"</b>	 Coarse	 Medium	 Fine	 Superfine
Code		SL1981/1958C	SL1981/1958M	SL1981/1958F	SL1981/1958SF
Description	<b>1/2"</b>	 Coarse	 Medium	 Fine	 Superfine
Code		SL1982/1958C	SL1982/1958M	SL1982/1958F	SL1982/1958SF

100 per package

## Composite Disc Mandrels (for use with Johnson-Promident Sof-Lex-type discs)



Description	RA Mandrel	HP Mandrel
Code	MAN-1958RA	MAN-1958HP

3 per package

## Finishing and Polishing Strips

Interproximal trimming, polishing, and finishing at a high level of polish and luster, gapped at the center for easy interproximal insertion.

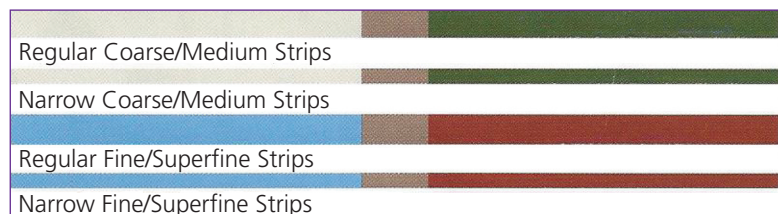

Description	Regular Coarse/ Medium Strips	Narrow Coarse/ Medium Strips	Regular Fine/ Superfine Strips	Narrow Fine/ Superfine Strips
Code	SL1954-C/M	SL1954N-C/M	SL1956-F/SF	SL1956N-F/SF

100 per package



## Complete Disc/Strip Kit

Contains 252 pieces:

- 200 discs (25 each of 3/8" and 1/2" in Coarse, Medium, Fine, and Superfine)
- 50 strips (25 each of Regular Coarse/Medium and Regular Fine/Superfine)
- 2 RA Mandrels

Code SL2385-KIT

*\*Note: Johnson-Promident Sof-Lex-type discs will not fit on Sof-Lex pop-on mandrels (they are 1958 type)*



# finishing and polishing INSTRUMENTS

## Separating Discs

**7/8"x.009** – Super thin and strong. Made of the purest silicon carbide abrasive for fine cutting and finishing of porcelain interproximals and margins. Will not discolor porcelain.

**7/8"x.015** – Very thin. Made with the purest silicon carbide abrasive to provide fast cool cutting of porcelain and gold. Will not discolor porcelain.

**7/8"x.025 – Ruby** – Made with aluminum oxide that has a ceramic coating for long lasting, fast cutting of all chrome, precious, and semi-precious metals. Compare to Dentsply Fastcut discs and Keystone Red Flush discs.

**7/8"x.025 – Stripper** – Made with brown aluminum oxide for fast cutting of all chrome, precious, and semi-precious metals.



Description	Separating Disc	Separating Disc
Size (inches)	7/8x.009	7/8x.015
Code	ST-SEPD09	VT-SEPD15

25 per package  
Maximum RPM 30,000

## Mandrel

Standard #303	HP Mandrel
Code	MAN-303HP



Description	Ruby	Stripper
Size (inches)	7/8x.025	7/8x.025
Code	RUBY-D025	STRIP-D025

100 per package  
Maximum RPM 30,000



## Strip Saw

7"x8mm wide stainless steel serrated saw for opening embrasures and easily opening contacts following restorative procedures.

Description	8mm Strip Saw
Code	SAW-8MM

6 per package



# finishing and polishing INSTRUMENTS



## Single-Use Diamond Composite Polishers, Dentsply PoGo/Enhance-Type

These disposable polishing systems are ideal for finishing and polishing all composites, creating a high-gloss luster even on the latest generation composite materials.

### Coarse, Dentsply Enhance-Type

Two-step polishing system for finishing and polishing all composite restorations. Provides an aesthetic high gloss finish.



Description	Disc	Cup	Point
Code	ENH-DISC	ENH-CUP	ENH-PT
Shank	RA	RA	RA

48 per package  
Recommended RPM 5,000-10,000



Use with **Deldent DiaGlaze Diamond Paste**, containing actual diamond particles for a superb, natural appearance.

Description	Extra Fine (2gm)	Fine (2gm)	Regular (2gm)	3-pack of Regular, Fine, Extra Fine (2gm ea)
Code	520005	520006	520007	520004



### Fine, Dentsply PoGo Type

One-step diamond polisher creates high luster on all composites without paste in one quick and easy step.



Description	Disc	Cup	Point
Code	POG-DISC	POG-CUP	POG-PT
Shank	RA	RA	RA

48 per package  
Recommended RPM 5,000-10,000

## Single-Use Diamond Composite Polishing Kit, Dentsply Enhance/PoGo-Type

Contains 60 pieces:  
10 each of cup, point, disc in both coarse and fine

Code      ENH/POG-KIT



# finishing and polishing





## INSTRUMENTS



### Two-Step Diamond Composite Polishers (Multi-Use)





Two-step diamond polishing system for finishing, smoothing and high-luster polishing of the latest generation of composite materials. Diamond abrasives are embedded in the four silicone polisher shapes to enable easy access to interproximal and occlusal surfaces.

#### Pre-Polishers, Coarse

				
Description	Small Point	Point	Cup	Knife Edge
Code	COMP-SPC	COMP-PC	COMP-CC	COMP-KEC
Shank	RA	RA	RA	RA

3 per package  
Recommended RPM 5,000-10,000

#### Polishers, Fine

				
Description	Small Point	Point	Cup	Knife Edge
Code	COMP-SPF	COMP-PF	COMP-CF	COMP-KEF
Shank	RA	RA	RA	RA

3 per package  
Recommended RPM 5,000-10,000



### Two-Step Diamond Composite Polishing Kit

Contains 8 pieces:  
1 each of small point, point, cup, and knife edge in both coarse and fine

Code COMP-KIT

Use with **Deldent Diaglaze Diamond Paste**, containing actual diamond particles for a superb, natural appearance

Description	Extra Fine (2gm)	Fine (2gm)	Regular (2gm)	3-pack of Regular, Fine, Extra Fine (2gm ea)
Code	520005	520006	520007	520004







# finishing and polishing





## INSTRUMENTS

### Amalgam/Gold Polishers, Shofu "Brownie- and Greenie-Type"





Three-step polishing system for fast removal, smoothing, and polishing of amalgam and precious metals. The silicon carbide is embedded in a medium-soft, flexible synthetic rubber matrix. Our coarse "Brownie"-type polishers produce a smooth surface, medium "Greenie"-type polishers produce a lustrous polish, and fine "Super-Greenie"-type polishers produce a super polish.

Shaping - Coarse				
				
Description	Mini Point	Point	Cup	Bullet
Code	AMAL-MP030C	AMAL-P050C	AMAL-C065C	AMAL-B040C
Shank	RA	RA	RA	RA

12 per package  
Recommended RPM 7,000-12,000

Smoothing - Medium				
				
Description	Mini Point	Point	Cup	Bullet
Code	AMAL-MP030M	AMAL-P050M	AMAL-C065M	AMAL-B040M
Shank	RA	RA	RA	RA

12 per package  
Recommended RPM 7,000-12,000

High Shine - Fine				
				
Description	Mini Point	Point	Cup	Bullet
Code	AMAL-MP030F	AMAL-P050F	AMAL-C065F	AMAL-B040F
Shank	RA	RA	RA	RA

12 per package  
Recommended RPM 7,000-12,000

### Amalgam/Gold Polishing Kit

Contains 12 pieces:  
1 each of mini point, point, cup, and bullet in coarse, medium, and fine

Code AM-GOLDKIT





# finishing and polishing INSTRUMENTS

## Porcelain Polishers



### Diamond Porcelain Polisher, NTI/Axis CeraGlaze-Type

Amazing three-step diamond polishing system for removing, finishing, and high-luster polishing of ceramic, metal, and zirconia. Diamond abrasive embedded in a hard-flexible, silicone polisher. No need for multiple polishing systems, and the high-luster polish is achieved without paste.

#### Shaping - Coarse

Description	Wheel	Small Point	Point	Cup	Disc
Code	CERA-W43C	CERA-SP33C	CERA-P32C	CERA-C55C	CERA-D36C
Shank	HP	RA	RA	RA	RA

3 per package

Recommended RPM 7,000-12,000

#### Smoothing - Medium

Description	Wheel	Small Point	Point	Cup	Disc
Code	CERA-W43M	CERA-SP33M	CERA-P32M	CERA-C55M	CERA-D36M
Shank	HP	RA	RA	RA	RA

3 per package

Recommended RPM 7,000-12,000

#### High Shine - Fine

Description	Wheel	Small Point	Point	Cup	Disc
Code	CERA-W43F	CERA-SP33F	CERA-P32F	CERA-C55F	CERA-D36F
Shank	HP	RA	RA	RA	RA

3 per package

Recommended RPM 7,000-12,000

### Diamond Porcelain Polishing Kit

Contains 12 pieces:

1 each of small point, point, cup, and disc in coarse, medium, and fine.

Code CERA506-KIT







# finishing and polishing

## INSTRUMENTS





### Standard Porcelain Polisher, Shofu Ceramiste/NTI Axis Porcelain-Type

Silicone polishers made specifically for polishing porcelain and enamel, with three grits for prepolishing, polishing, and high shine super polishing.

Shaping - Coarse					
					
Description	Wheel	Small Point	Point	Cup	Disc
Code	PORC-W43C	PORC-SP33C	PORC-P32C	PORC-C55C	PORC-D36C
Shank	HP	RA	RA	RA	RA





**10 per package**

Recommended RPM 7,000-12,000

Smoothing - Medium					
					
Description	Wheel	Small Point	Point	Cup	Disc
Code	PORC-W43M	PORC-SP33M	PORC-P32M	PORC-C55M	PORC-D36M
Shank	HP	RA	RA	RA	RA

**10 per package**

Recommended RPM 7,000-12,000

High Shine - Fine					
					
Description	Wheel	Small Point	Point	Cup	Disc
Code	PORC-W43F	PORC-SP33F	PORC-P32F	PORC-C55F	PORC-D36F
Shank	HP	RA	RA	RA	RA

**10 per package**

Recommended RPM 7,000-12,000

### Standard Porcelain Polishing Kit

Contains 12 pieces:

1 each of small point, point, cup, and disc in coarse, medium, and fine.





Code            PORC-KIT

# finishing and polishing INSTRUMENTS

## Acrylic Polishers, NTI/Axis-Type





Three-step polishing system for removing, finishing, and high-luster polishing of acrylics. Silicon carbide embedded in a medium-soft, flexible, synthetic rubber matrix.

### Shaping - Coarse

				
Description	Small Point	Point	Large Point	Jumbo
Code	ACR-SP9580C	ACR-P679C	ACR-LP674C	ACR-J672C
Shank	HP	HP	HP	HP





6 per package  
Recommended RPM 5,000-7,000

### Smoothing - Medium

				
Description	Small Point	Point	Large Point	Jumbo
Code	ACR-SP9580M	ACR-P669M	ACR-LP664M	ACR-J662M
Shank	HP	HP	HP	HP

6 per package  
Recommended RPM 5,000-7,000

### High Shine - Fine

				
Description	Small Point	Point	Large Point	Jumbo
Code	ACR-SP9580F	ACR-P659F	ACR-LP654F	ACR-J652F
Shank	HP	HP	HP	HP

6 per package  
Recommended RPM 5,000-7,000

## Silicone Acrylic Polishing Kit

Contains 12 pieces:  
1 each of small point, point, large point, and jumbo  
in coarse, medium, and fine.

Code ACR-KIT









# finishing and polishing INSTRUMENTS

## Green and White Stones, Shofu Dura-Green- and Dura-White-Type

Green Stones contain silicon carbide and are excellent for fast contouring and finishing of porcelain, composites, and gold and silver alloys. White Stones, made of aluminum oxide, are ideal for fine contouring and finishing of enamel, composites, and porcelains.

### Green Stones

							
Description	CY-3	TC-2	TC-4	IC-3	IC-5	IC-7	IC-9
Code	G-CY3HP-12	G-TC2HP-12	G-TC4HP-12	G-IC3HP-12	G-IC5HP-12	G-IC7HP-12	G-IC9HP-12
Shank	HP	HP	HP	HP	HP	HP	HP







12 per package  
Recommended RPM 8,000-12,000

### Green Stones (continued)

						
Description	KN-7	PC-2	WH-3	WH-6	CN1	FL2
Code	G-KN7HP-12	G-PC2HP-12	G-WH3HP-12	G-WH6HP-12	G-CN1FG-12	G-FL2FG-12
Shank	HP	HP	HP	HP	FG	FG

12 per package  
Recommended RPM 8,000-12,000

### White Stones

						
Description	WH-6	TC-4	FL-3	IC-4	CN1	FL2
Code	W-WH6HP-12	W-TC4HP-12	W-FL3HP-12	W-IC4HP-12	W-CN1FG-12	W-FL2FG-12
Shank	HP	HP	HP	HP	FG	FG



12 per package  
Recommended RPM 8,000-12,000

# finishing and polishing INSTRUMENTS





## Zirconia/CAD/CAM Ceramic Abrasives

High performance synthetically bound diamond abrasives for latest generation materials. Specially designed for zirconia and alumina restorations without generating heat. Coarse abrasives for gross reduction, medium abrasives for finishing. For polishing, use Johnson-Promident Porcelain Polishers.

Coarse		
		
Description	Disc	Cone
Code	ZIRC-DC	ZIRC-CC
Shank	RA	RA

3 per package  
Recommended RPM 8,000-12,000

Medium		
		
Description	Disc	Cone
Code	ZIRC-DM	ZIRC-CM
Shank	RA	RA

3 per package  
Recommended RPM 8,000-12,000



### Ceramic Abrasives Kit

Contains 4 pieces:  
1 each of disc and cone in coarse and medium

Code                      ZIRC-KIT

Use with **Deldent DiaGlaze Diamond Paste**, containing actual diamond particles for a superb, natural appearance.

Description	Extra Fine (2gm)	Fine (2gm)	Regular (2gm)	3-pack Regular, Fine, Extra Fine (2gm each)
Code	520005	520006	520007	520004





# JOHNSON-PROMIDENT

## ABOUT US

For almost forty years, Johnson-Promident has been the trusted source for handpieces, replacement parts, and accessories. We have focused on the handpiece category since its inception, enabling us to assemble the broadest product line in the U.S. With the most recent additions to our line we now offer over 1,000 products!

We recently joined together with Deldent of Israel, and the addition of Deldent's cutting edge scaling and polishing products makes Johnson-Promident a one-stop shop for small equipment and related accessories.

Our full line of top-rated carbide burs\* and our new lines of diamond burs and finishing and polishing instruments are featured in this catalog. These product lines now allow us to offer the most comprehensive array of rotary instruments in existence!

Johnson-Promident is a leading OEM and private label supplier to many of the best known manufacturers and dealers in dentistry. Our flexible manufacturing capabilities enable us to meet a wider range of custom requirements.

Johnson-Promident also benefits from being part of a larger organization that includes a sister company in the dental industry, JP Solutions. JP Solutions is a leading private label and branded provider of infection control, evacuation, and disposable products.

Our long-standing success has been fueled by our superior customer service, wide ranging product availability, global manufacturing capabilities, and products that provide excellent value. We are committed to providing you with the best products at the best prices!

Please contact us or visit our website to request our other product catalogs:

**Johnson-Promident** – our complete catalog of handpieces, replacement parts, and accessories



**Deldent** – scaling and polishing products



**JP Solutions** – infection control, evacuation, and disposable products

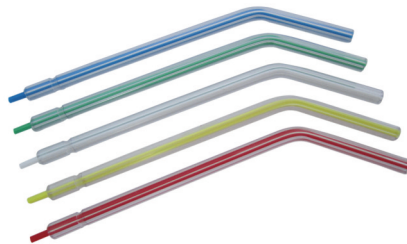

*\*2012 Best Product rating from Dental Product Shopper, the highest rated carbide bur.*



Johnson-Promident 707 Executive Boulevard, Unit D Valley Cottage, NY 10989  
TEL 800 210-8945 FAX 800 922-4898  
[www.johnsonpromident.com](http://www.johnsonpromident.com)